

# Parts List

## H.HM-110

### Micromotor Hammer Handpiece

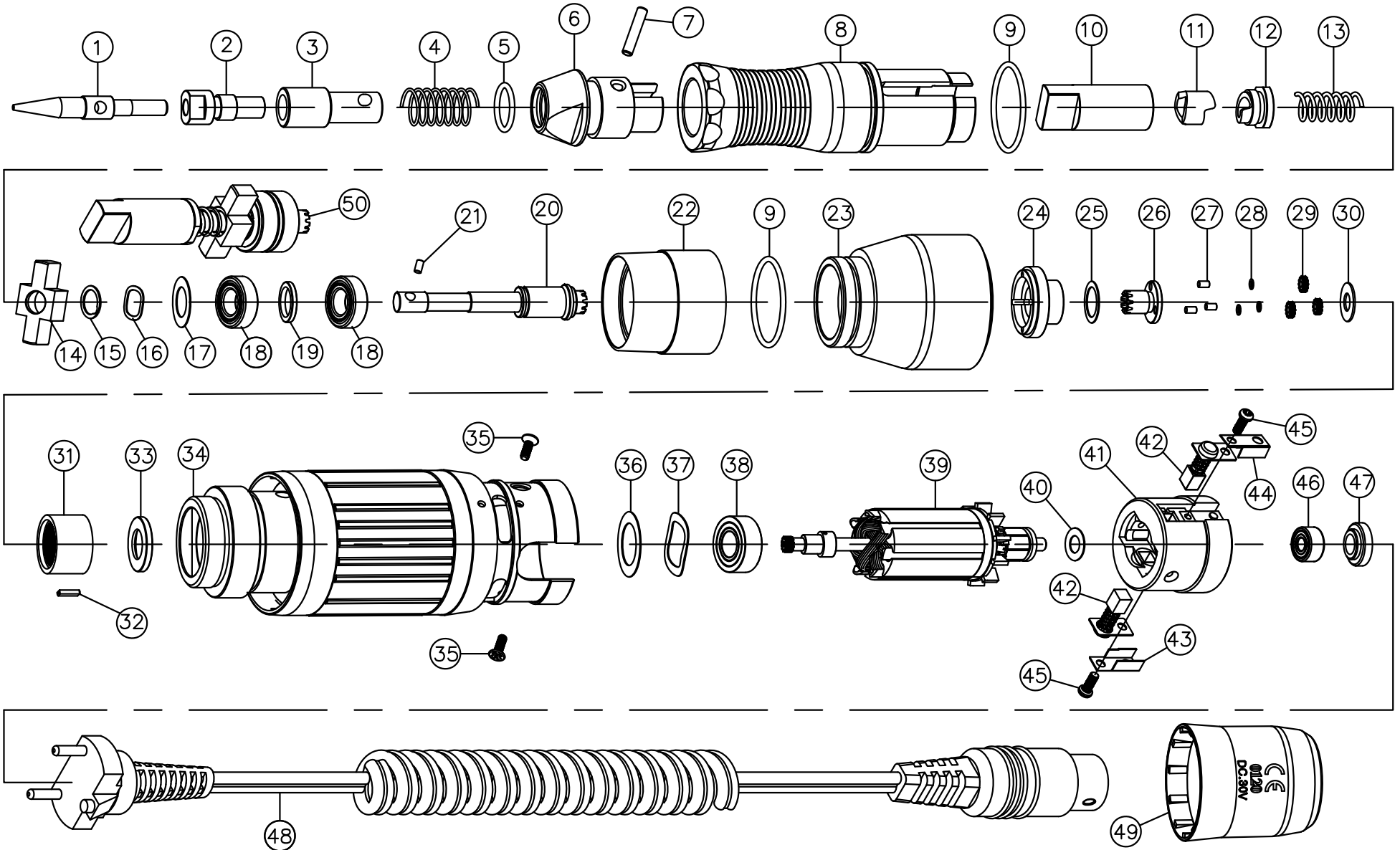

**FOREDOM<sup>®</sup>** Foredom Electric Company

16 Stony Hill Rd, Bethel, CT 06801  
 Tel: 203-792-8622 Fax: 203-796-7861  
 web: www.foredom.net

# Parts List

## H.HM-110

### Micromotor Hammer Handpiece

Item	Foredom P/N	Description	Qty
1		ANVIL POINT	1
2		HAMMER ADAPTER	1
3		PLUNGER	1
4		PLUNGER SPRING	1
5		O-RING, NOSEPIECE	1
6		NOSEPIECE	1
7		PIN	1
8		HAND CAP	1
9	HP7-5027	O-RING, CAM	2
10		CAM HOUSING	1
11		CAM B	1
12		CAM A	1
13		CAM SPRING	1
14		IMPACT ADJUSTMENT SCREW	1
15	HP4-104	CHUCK HOUSING C-RING	1
16	HP7-3103	WAVY WASHER, 1260	1
17	HP4-111	FLAT WASHER, 1260	1
18	HP4-201	BALL BEARING (1260ZZ)	2
19		SPACER	1
20		SPINDLE	1
21		CAM PIN	1
22		IMPACT ADJUSTING RING	1
23		GEAR CASE	1
24		BEARING SEAT	1
25		WASHER, 1060	1

Item	Foredom P/N	Description	Qty
26		OUTPUT GEAR	1
27		SHAFT, PLANET GEAR	3
28		PLANETARY GEAR SPACER	3
29		PLANETARY GEAR	3
30		GEAR SPACER	2
31		RING GEAR	1
32		KEY	1
33		RING GEAR SPACER	1
34		MOTOR CASE ASSEMBLY	1
35	HP4-205	MOTOR CASE BOLT	2
36		CONTROL WASHER	1
37		WAVE WASHER	1
38	HP7-8033	BALL BEARING (1360ZZ)	1
39		ARMATURE ASSEMBLY	1
40		TEFLON WASHER	1
41	HP4-172A	HOUSING, BEARING	1
42	HP4-163	CARBON BRUSH (PAIR)	1
43		TERMINAL (LEFT)	1
44		TERMINAL(RIGHT)	1
45	HP4-206	CARBON BRUSH BOLT	2
46	HP4-208	BALL BEARING (1030ZZ)	1
47		BEARING BUSH BOLT	1
48	HP4-174	ELECTRICAL CORD	1
49		CARBON HOUSING COVER	1
50	HP1-153	HAMMER MECHANISM	1

**FOREDOM<sup>®</sup>** Foredom Electric Company

16 Stony Hill Rd, Bethel, CT 06801  
 Tel: 203-792-8622 Fax: 203-796-7861  
 web: www.foredom.net